



VENT 100 - 315



VENT 355 - 400

## APPLICATION

VENT series fans are used in a variety of mechanical ventilation systems. Examples of use: supply and exhaust ventilation of flats, offices, shops, bars, cafes and restaurants. In addition it can be used in cooling systems, local extractors, workshop ventilation and cloakrooms.

## CONSTRUCTION

Radial duct fans of the VENT series are available in 9 versions, in nominal diameters: 100, 125, 150, 160, 200, 250, 315, 355, 400 mm. All are equipped with single-phase electric motors. VENT series models from 100 to 315 contain casings made of galvanized sheet steel and impellers made of polyamide. Models 355 and 400 contain casings made of sheet steel painted black and aluminium impellers. A mounting strip and a junction box with 800 mm power cord are included with models 100 to 315. The junction box is mounted to the casing on the 355 and 400 models. The impellers with backward curved blades are designed for transporting maximum air volume at high static pressure with minimum noise level.

## MOTOR

All models of VENT fans employ rotary stator motors. Single-phase 230V 50 / 60Hz motors in all models. Models 100-315 are equipped with motors with IP44 protection rating and insulation class B, models 355-400 with motors with IP54 protection rating and insulation class F. Standard motors are equipped with thermal overload protection. All motors are suitable for voltage speed control.



## Mounting foot

Supplied with unit as standard (100-315 models).



WWW



DTR



CE

## TECHNICAL CHARACTERISTICS

Type	run	speed	maximum absorbed power	maximum absorbed current	airflow at free discharge	sound pressure level*	operating temperature		weight	regulator	ErP	article number
		[r.p.m.]	[W]	[A]	[m <sup>3</sup> /h]	[dB(A)]	min	max				
VENT-100N	230	2600	61	0,27	290	38	-20	+60	3	TLR 15 DS RVS-1,5	2016	40022200
	170	2320	44	0,25	260	35						
	140	1980	37	0,25	220	30						
VENT-125N	230	2620	60	0,27	390	36	-20	+60	3	TLR 15 DS RVS-1,5	2016	40022210
	170	2350	44	0,25	340	34						
	140	2020	37	0,25	290	30						
VENT-150N	230	2550	95	0,4	750	36	-20	+60	5	TLR 15 DS RVS-1,5	2018	40022211
	170	2110	72	0,41	610	32						
	140	1660	55	0,38	480	27						
VENT-160N	230	2560	96	0,4	760	37	-20	+60	5	TLR 15 DS RVS-1,5	2018	40022212
	170	2140	72	0,41	640	33						
	140	1680	56	0,38	500	28						
VENT-200N	230	2720	147	0,6	970	37	-20	+60	5	TLR 15 DS RVS-1,5	2018	40022213
	170	2490	119	0,7	870	35						
	140	2150	98	0,6	760	32						
VENT-250N	230	2720	149	0,6	1030	44	-20	+60	6	TLR 15 DS RVS-1,5	2018	40022214
	170	2460	122	0,7	920	42						
	140	2170	101	0,7	800	39						
VENT-315N	230	2790	257	1,1	1370	42	-20	+60	8	TLR 15 DS RVS-1,5	2018	40022215
	170	2610	213	1,2	1250	41						
	140	2380	180	1,3	1150	39						
VENT-355N	230	1370	278	1,2	2600	34	-40	+70	18,8	TLR 15 DS RVS-1,5	2018	40022216
	170	1250	227	1,3	2320	32						
	140	1100	195	1,4	2050	29						
VENT-400N	230	1380	534	2,3	3800	43	-20	+50	22,2	TLR 25 DS RVS-3	2018	40022217
	170	1200	481	3	3250	40						
	140	830	362	2,9	2230	32						

\* Measured at a distance of 3m from the fan.

## PERFORMANCE CURVES

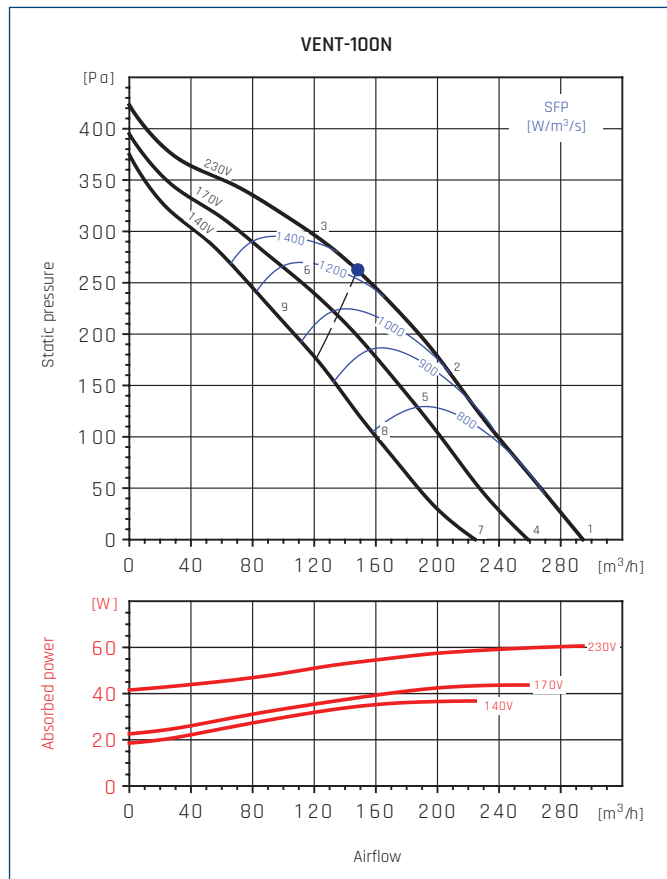

● - highest efficiency point

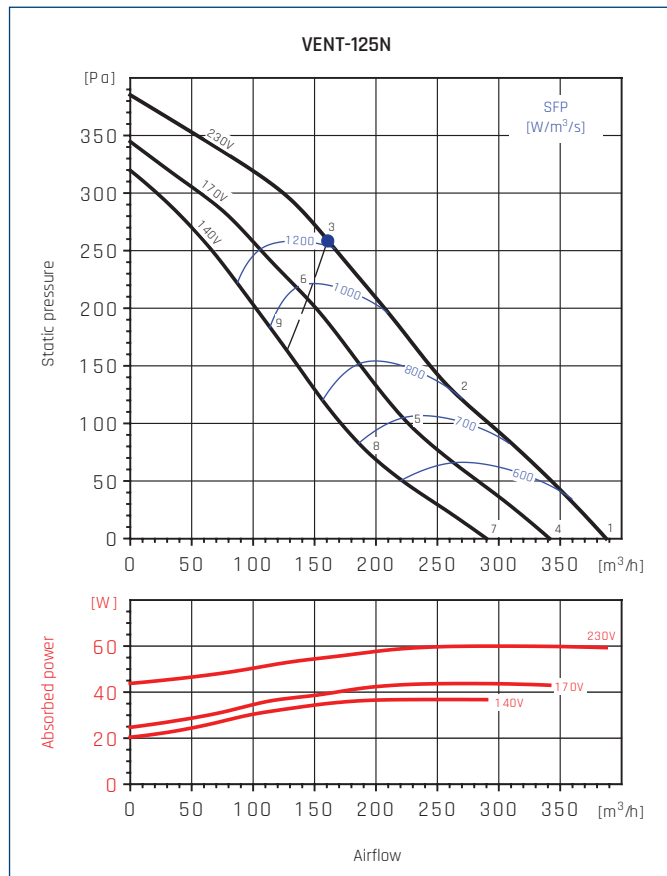

● - highest efficiency point

## ACOUSTIC CHARACTERISTICS

Hz/dB(A)	65	125	250	500	1000	2000	4000	8000	$L_{WA}$	
1	Inlet	37	46	58	62	68	64	60	45	71
	Outlet	37	45	63	58	63	61	57	46	68
	Emitted	33	38	50	50	55	49	51	37	59
2	Inlet	39	45	56	60	66	62	56	43	69
	Outlet	38	44	61	56	61	59	54	43	66
	Emitted	35	37	48	48	53	47	47	34	56
3	Inlet	37	43	53	58	65	60	53	42	67
	Outlet	37	43	57	56	60	57	52	42	64
	Emitted	33	35	45	46	52	45	44	33	55
4	Inlet	35	43	55	59	65	61	56	41	68
	Outlet	35	42	60	55	60	58	53	41	65
	Emitted	31	35	47	47	52	46	47	32	55
5	Inlet	36	42	54	57	63	60	52	39	66
	Outlet	36	42	59	53	58	56	50	39	63
	Emitted	32	34	46	45	50	45	43	30	54
6	Inlet	34	40	52	56	63	58	50	39	65
	Outlet	35	41	56	53	58	55	49	40	62
	Emitted	30	32	44	44	50	43	41	30	53
7	Inlet	32	39	51	55	60	57	49	34	63
	Outlet	31	39	56	50	55	53	46	34	60
	Emitted	28	31	43	43	47	42	40	25	51
8	Inlet	32	38	49	53	59	55	45	32	62
	Outlet	32	39	54	49	54	51	44	32	59
	Emitted	28	30	41	41	46	40	36	23	49
9	Inlet	32	37	49	52	61	55	46	35	63
	Outlet	32	39	54	50	56	52	45	35	60
	Emitted	28	29	41	40	48	40	37	26	50

Hz/dB(A)	65	125	250	500	1000	2000	4000	8000	$L_{WA}$	
1	Inlet	33	42	54	64	67	66	62	49	71
	Outlet	33	43	61	62	63	62	59	47	69
	Emitted	20	34	49	45	53	49	50	37	57
2	Inlet	34	42	53	64	66	64	58	47	70
	Outlet	34	43	59	62	62	60	56	45	67
	Emitted	21	34	48	45	52	47	46	35	55
3	Inlet	35	43	53	64	65	61	54	43	69
	Outlet	35	44	60	62	61	58	53	44	67
	Emitted	22	35	48	45	51	44	42	31	54
4	Inlet	31	40	52	62	65	64	60	47	69
	Outlet	31	41	59	60	61	60	57	45	66
	Emitted	18	32	47	43	51	47	48	35	55
5	Inlet	32	40	51	62	64	62	56	45	67
	Outlet	31	40	56	59	59	57	53	42	65
	Emitted	19	32	46	43	50	45	44	33	53
6	Inlet	33	41	51	62	63	59	52	41	67
	Outlet	33	42	58	60	59	56	51	42	65
	Emitted	20	33	46	43	49	42	40	29	53
7	Inlet	27	36	48	58	61	60	56	43	66
	Outlet	27	37	55	56	57	56	53	41	63
	Emitted	14	28	43	39	47	43	44	31	51
8	Inlet	28	36	47	58	60	58	52	41	64
	Outlet	28	37	53	56	56	54	50	39	61
	Emitted	15	28	42	39	46	41	40	29	49
9	Inlet	31	39	49	60	61	57	50	39	65
	Outlet	31	40	56	58	57	54	49	40	63
	Emitted	18	31	44	41	47	40	38	27	50

## PERFORMANCE CURVES

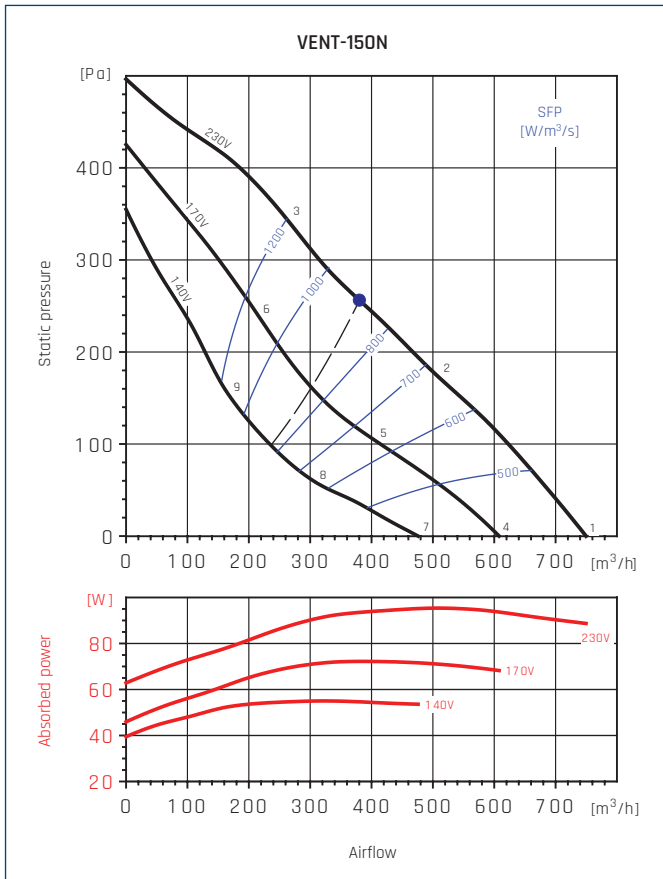

● - highest efficiency point

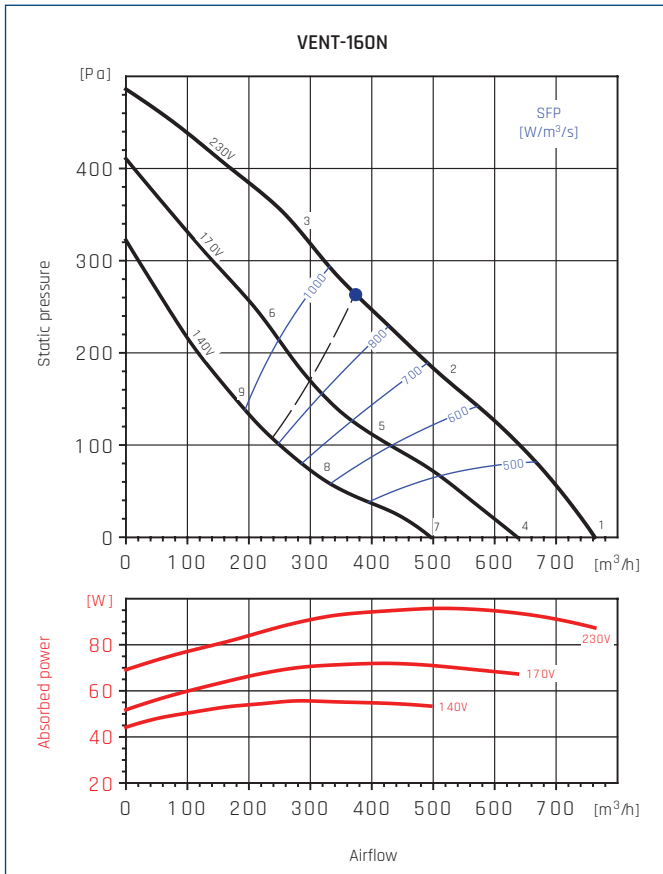

● - highest efficiency point

## ACOUSTIC CHARACTERISTICS

Hz/dB(A)	65	125	250	500	1000	2000	4000	8000	$L_{WA}$	
1	Inlet	37	45	58	69	68	67	63	51	73
	Outlet	37	48	62	63	64	64	61	51	70
	Emitted	21	37	45	49	50	51	49	37	56
2	Inlet	35	44	58	68	67	65	60	48	72
	Outlet	35	47	59	62	63	63	58	48	69
	Emitted	19	36	45	48	49	49	46	34	55
3	Inlet	37	48	60	68	66	65	57	47	72
	Outlet	36	49	61	61	62	61	55	46	68
	Emitted	21	40	47	48	48	49	43	33	55
4	Inlet	33	41	54	65	64	63	59	47	70
	Outlet	33	44	58	59	60	60	57	47	66
	Emitted	17	33	41	45	46	47	45	33	52
5	Inlet	30	39	53	63	62	60	55	43	67
	Outlet	30	42	54	57	58	58	53	43	64
	Emitted	14	31	40	43	44	44	41	29	50
6	Inlet	33	44	56	64	62	61	53	43	68
	Outlet	33	46	58	58	59	58	52	43	64
	Emitted	17	36	43	44	44	45	39	29	51
7	Inlet	28	36	49	60	59	58	54	42	64
	Outlet	28	39	53	54	55	55	52	42	61
	Emitted	12	28	36	40	41	42	40	28	47
8	Inlet	24	33	47	57	56	54	49	37	62
	Outlet	24	36	48	51	52	52	47	37	58
	Emitted	8	25	34	37	38	38	35	23	44
9	Inlet	28	39	51	59	57	56	48	38	63
	Outlet	28	41	53	53	54	53	47	38	59
	Emitted	12	31	38	39	39	40	34	24	46

Hz/dB(A)	65	125	250	500	1000	2000	4000	8000	$L_{WA}$	
1	Inlet	36	45	58	68	67	67	65	53	73
	Outlet	38	47	61	62	64	64	62	52	70
	Emitted	22	37	46	50	53	52	50	41	58
2	Inlet	33	45	57	68	67	65	61	50	72
	Outlet	34	47	57	63	63	63	58	49	69
	Emitted	19	37	45	50	53	50	46	38	57
3	Inlet	37	48	58	67	65	64	57	47	71
	Outlet	37	51	62	63	63	61	55	46	69
	Emitted	23	40	46	49	51	49	42	35	55
4	Inlet	32	41	54	64	63	63	61	49	69
	Outlet	34	43	57	58	60	60	58	48	66
	Emitted	18	33	42	46	49	48	46	37	54
5	Inlet	28	40	52	63	62	60	56	45	67
	Outlet	29	42	52	58	58	58	53	44	64
	Emitted	14	32	40	45	48	45	41	33	52
6	Inlet	33	44	54	63	61	60	53	43	67
	Outlet	33	47	58	59	59	57	51	42	65
	Emitted	19	36	42	45	47	45	38	31	51
7	Inlet	27	36	49	59	58	58	56	44	64
	Outlet	29	38	52	53	55	55	53	43	61
	Emitted	13	28	37	41	44	43	41	32	49
8	Inlet	22	34	46	57	56	54	50	39	62
	Outlet	24	37	47	53	53	53	48	39	58
	Emitted	8	26	34	39	42	39	35	27	46
9	Inlet	28	39	49	58	56	55	48	38	62
	Outlet	28	42	53	54	54	52	46	37	60
	Emitted	14	31	37	40	42	40	33	26	47

## PERFORMANCE CURVES

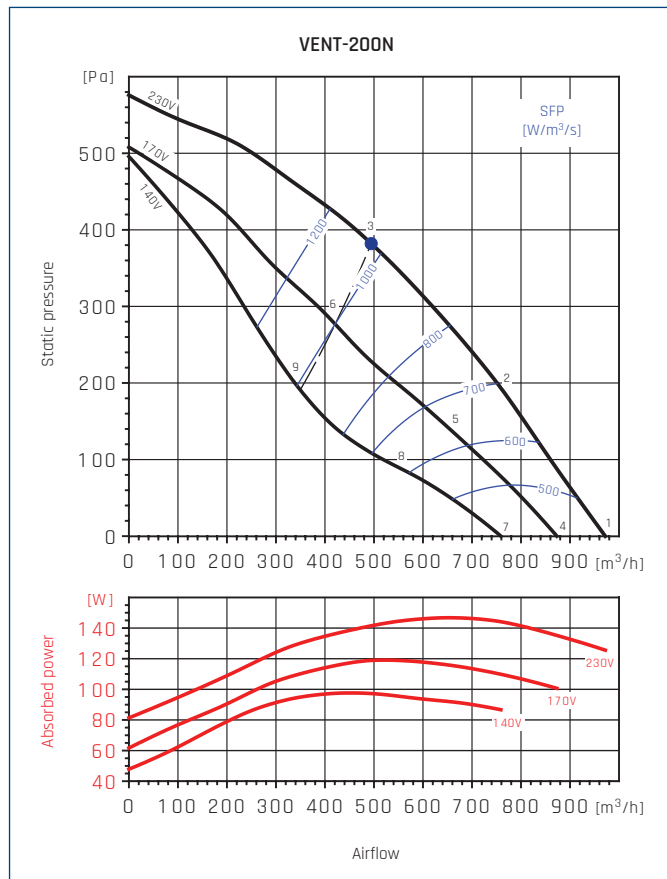

● - highest efficiency point

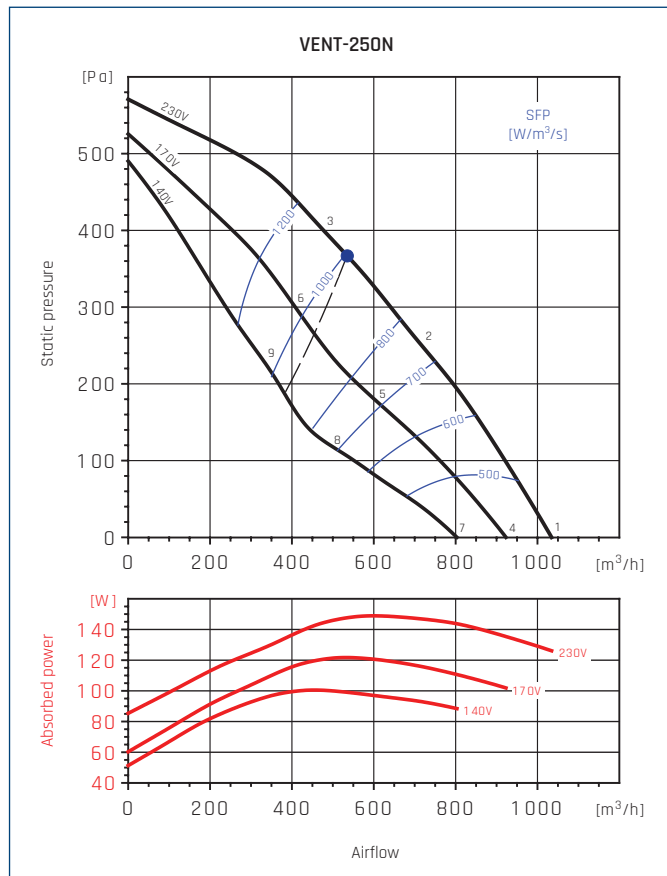

● - highest efficiency point

## ACOUSTIC CHARACTERISTICS

Hz/dB(A)		65	125	250	500	1000	2000	4000	8000	L <sub>WA</sub>
1	Inlet	38	48	63	67	70	68	65	63	75
	Outlet	37	47	61	63	67	67	65	62	73
	Emitted	36	39	44	38	48	52	54	48	58
2	Inlet	36	46	62	64	67	64	61	55	71
	Outlet	37	46	62	61	63	63	61	54	69
	Emitted	34	37	43	35	45	48	50	40	54
3	Inlet	37	46	60	63	65	62	57	50	69
	Outlet	35	46	61	59	62	62	58	50	68
	Emitted	35	37	41	34	43	46	46	35	51
4	Inlet	36	46	61	65	68	66	63	61	73
	Outlet	36	46	60	62	66	66	64	61	71
	Emitted	34	37	42	36	46	50	52	46	56
5	Inlet	33	43	59	61	64	61	58	52	68
	Outlet	34	43	59	58	60	60	58	51	66
	Emitted	31	34	40	32	42	45	47	37	51
6	Inlet	34	43	57	60	62	59	54	47	67
	Outlet	32	43	58	56	59	59	55	47	65
	Emitted	32	34	38	31	40	43	43	32	48
7	Inlet	33	43	58	62	65	63	60	58	70
	Outlet	32	42	56	58	62	62	60	57	68
	Emitted	31	34	39	33	43	47	49	43	53
8	Inlet	29	39	55	57	60	57	54	48	64
	Outlet	30	39	55	54	56	56	54	47	62
	Emitted	27	30	36	28	38	41	43	33	47
9	Inlet	30	39	53	56	58	55	50	43	63
	Outlet	28	39	54	52	55	55	51	43	61
	Emitted	28	30	34	27	36	39	39	28	44

Hz/dB(A)		65	125	250	500	1000	2000	4000	8000	L <sub>WA</sub>
1	Inlet	37	48	65	68	72	70	68	65	77
	Outlet	40	51	66	67	69	69	69	66	76
	Emitted	22	39	49	50	58	59	59	56	64
2	Inlet	36	46	63	64	68	66	66	59	73
	Outlet	39	49	63	63	65	64	66	59	72
	Emitted	21	37	47	46	54	55	57	50	61
3	Inlet	35	43	61	61	66	63	62	54	70
	Outlet	37	46	62	62	65	64	62	55	70
	Emitted	20	34	45	43	52	52	53	45	58
4	Inlet	35	46	63	66	70	68	66	63	74
	Outlet	38	49	64	65	67	67	67	64	74
	Emitted	20	37	47	48	56	57	57	54	62
5	Inlet	33	43	60	61	65	63	63	56	70
	Outlet	36	46	60	60	62	61	63	56	69
	Emitted	18	34	44	43	51	52	54	47	58
6	Inlet	32	40	58	58	63	60	59	51	67
	Outlet	34	43	59	59	62	61	59	52	67
	Emitted	17	31	42	40	49	49	50	42	55
7	Inlet	32	43	60	63	67	65	63	60	72
	Outlet	35	46	61	62	64	64	64	61	71
	Emitted	17	34	44	45	53	54	54	51	60
8	Inlet	29	39	56	57	61	59	59	52	66
	Outlet	32	42	56	56	58	57	59	52	64
	Emitted	14	30	40	39	47	48	50	43	54
9	Inlet	28	36	54	54	59	56	55	47	63
	Outlet	30	39	55	55	58	57	55	48	64
	Emitted	13	27	38	36	45	45	46	38	51

## PERFORMANCE CURVES

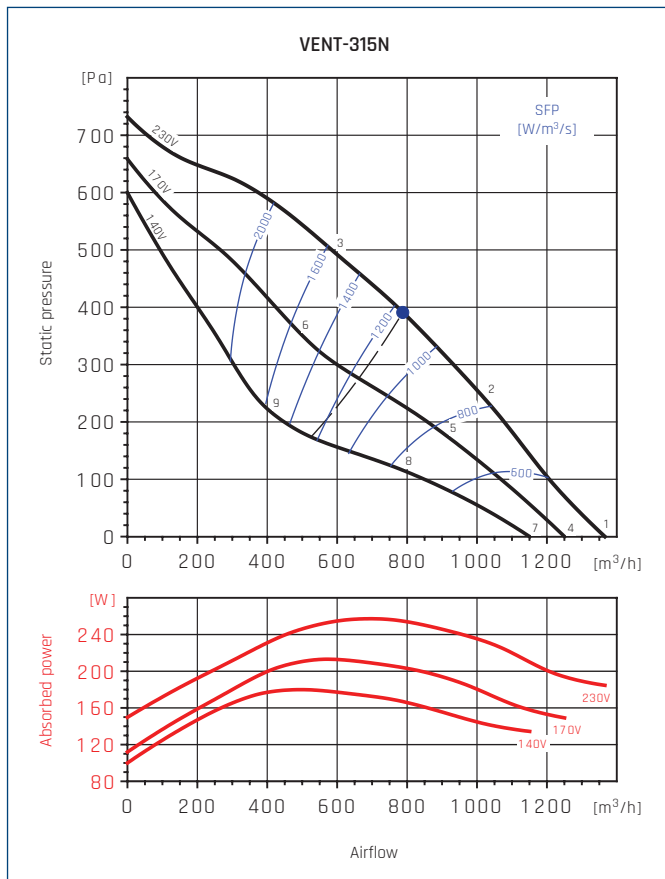

● - highest efficiency point

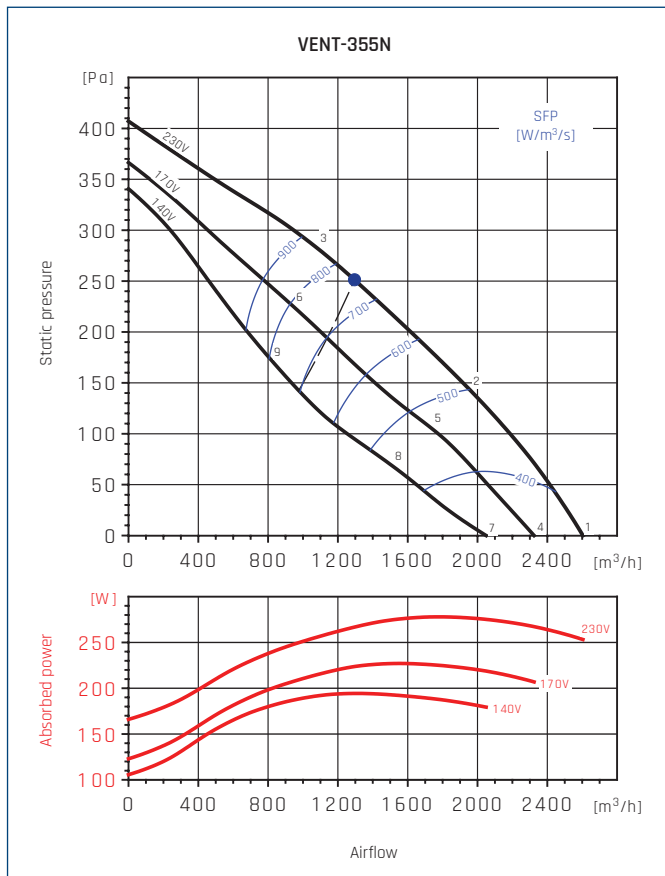

● - highest efficiency point

## ACOUSTIC CHARACTERISTICS

Hz/dB(A)		65	125	250	500	1000	2000	4000	8000	L <sub>WA</sub>
1	Inlet	39	53	67	73	76	71	68	67	79
	Outlet	48	54	69	71	75	74	70	70	80
	Emitted	29	33	45	51	58	57	55	54	63
2	Inlet	38	55	67	73	73	69	67	63	78
	Outlet	49	55	70	71	74	72	69	64	79
	Emitted	28	35	45	51	55	55	54	50	61
3	Inlet	42	64	71	73	74	70	67	60	79
	Outlet	50	64	74	71	74	72	68	62	80
	Emitted	32	44	49	51	56	56	54	47	61
4	Inlet	38	52	66	72	75	70	67	66	78
	Outlet	47	53	68	70	74	73	69	69	79
	Emitted	28	32	44	50	57	56	54	53	61
5	Inlet	36	53	65	71	71	67	65	61	75
	Outlet	46	52	67	68	71	69	66	61	76
	Emitted	26	33	43	49	53	53	52	48	58
6	Inlet	39	61	68	70	71	67	64	57	76
	Outlet	47	61	71	68	71	69	65	59	76
	Emitted	29	41	46	48	53	53	51	44	58
7	Inlet	36	50	64	70	73	68	65	64	76
	Outlet	45	51	66	68	72	71	67	67	77
	Emitted	26	30	42	48	55	54	52	51	59
8	Inlet	31	48	60	66	66	62	60	56	71
	Outlet	42	48	63	64	67	65	62	57	72
	Emitted	21	28	38	44	48	48	47	43	54
9	Inlet	34	56	63	65	66	62	59	52	71
	Outlet	42	56	66	63	66	64	60	54	72
	Emitted	24	36	41	43	48	48	46	39	53

Hz/dB(A)		65	125	250	500	1000	2000	4000	8000	L <sub>WA</sub>
1	Inlet	43	60	65	67	67	62	61	48	72
	Outlet	42	57	64	70	71	68	61	50	75
	Emitted	34	50	47	47	49	42	40	28	55
2	Inlet	39	57	63	65	66	60	57	48	70
	Outlet	39	55	64	70	69	66	58	49	74
	Emitted	30	47	45	45	48	40	36	28	53
3	Inlet	44	59	66	67	67	60	57	48	72
	Outlet	42	56	65	71	69	66	59	50	75
	Emitted	35	49	48	47	49	40	36	28	55
4	Inlet	41	58	63	65	65	60	59	46	70
	Outlet	40	55	62	68	69	66	59	48	73
	Emitted	32	48	45	45	47	40	38	26	53
5	Inlet	37	55	61	63	64	58	55	46	68
	Outlet	37	53	62	68	67	64	56	47	72
	Emitted	28	45	43	43	46	38	34	26	50
6	Inlet	42	57	64	65	65	58	55	46	70
	Outlet	40	54	63	69	67	64	57	48	73
	Emitted	33	47	46	45	47	38	34	26	53
7	Inlet	38	55	60	62	62	57	56	43	68
	Outlet	37	52	59	65	66	63	56	45	71
	Emitted	29	45	42	42	44	37	35	23	50
8	Inlet	33	51	57	59	60	54	51	42	65
	Outlet	33	49	58	64	63	60	52	43	68
	Emitted	24	41	39	39	42	34	30	22	47
9	Inlet	39	54	61	62	62	55	52	43	67
	Outlet	37	51	60	66	64	61	54	45	70
	Emitted	30	44	43	42	44	35	31	23	50

## PERFORMANCE CURVES

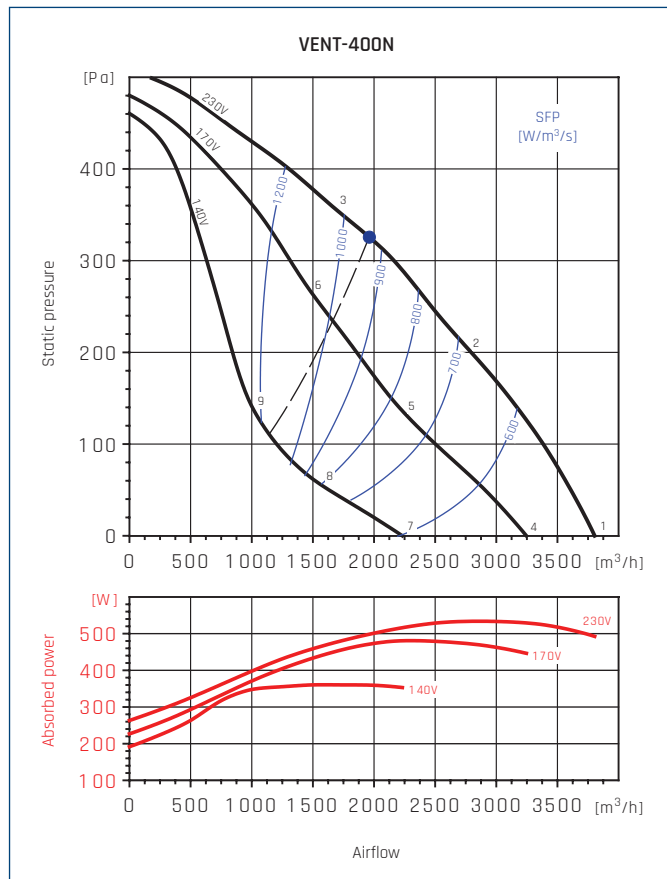

● - highest efficiency point

## DIMENSIONS [mm]

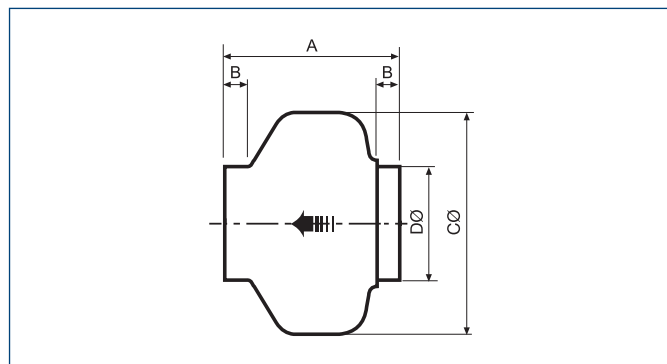

Type	A	B	ØC	ØD
VENT-100 N	195	23	243	98
VENT-125 N	197	27	243	123
VENT-150 N	213	22	333	147
VENT-160 N	220	27	333	157
VENT-200 N	223	25	333	198
VENT-250 N	205	27	333	248
VENT-315 N	232	25	401	312

## ACOUSTIC CHARACTERISTICS

Hz/dB(A)	65	125	250	500	1000	2000	4000	8000	L <sub>WA</sub>	
1	Inlet	47	61	65	69	67	64	61	53	73
	Outlet	52	68	68	72	73	69	61	54	78
	Emitted	38	56	53	57	59	52	46	40	63
2	Inlet	43	58	62	64	64	62	57	50	70
	Outlet	44	66	64	67	69	65	57	49	74
	Emitted	34	53	50	52	56	50	42	37	60
3	Inlet	46	60	64	66	64	60	55	50	71
	Outlet	47	65	65	68	68	63	55	47	73
	Emitted	37	55	52	54	56	48	40	37	61
4	Inlet	44	58	62	66	64	61	58	50	70
	Outlet	49	65	65	69	70	66	58	51	75
	Emitted	35	53	50	54	56	49	43	37	60
5	Inlet	39	54	58	60	60	58	53	46	66
	Outlet	40	62	60	63	65	61	53	45	69
	Emitted	30	49	46	48	52	46	38	33	56
6	Inlet	43	57	61	63	61	57	52	47	68
	Outlet	44	62	62	65	65	60	52	44	70
	Emitted	34	52	49	51	53	45	37	34	58
7	Inlet	36	50	54	58	56	53	50	42	62
	Outlet	41	57	57	61	62	58	50	43	67
	Emitted	27	45	42	46	48	41	35	29	52
8	Inlet	30	45	49	51	51	49	44	37	57
	Outlet	31	53	51	54	56	52	44	36	61
	Emitted	21	40	37	39	43	37	29	24	47
9	Inlet	36	50	54	56	54	50	45	40	60
	Outlet	37	55	55	58	58	53	45	37	63
	Emitted	27	45	42	44	46	38	30	27	50

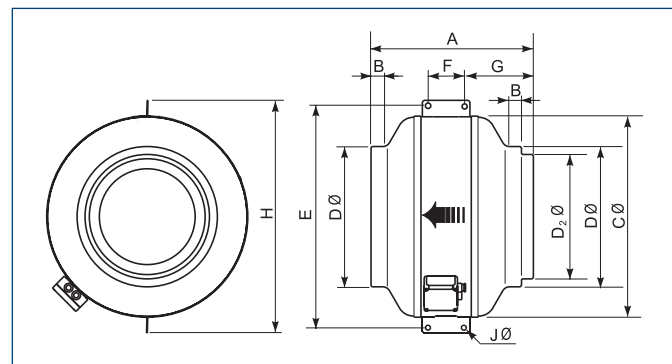

Type	A	B	ØC	ØD	ØD <sub>2</sub>	E	F	G	H	ØJ
VENT-355N	410	25	508	354	314	552	100	170	587	10,5
VENT-400N	431	25	568	399	354	628	100	185	647	10,5

## ACCESSORY ASSEMBLY

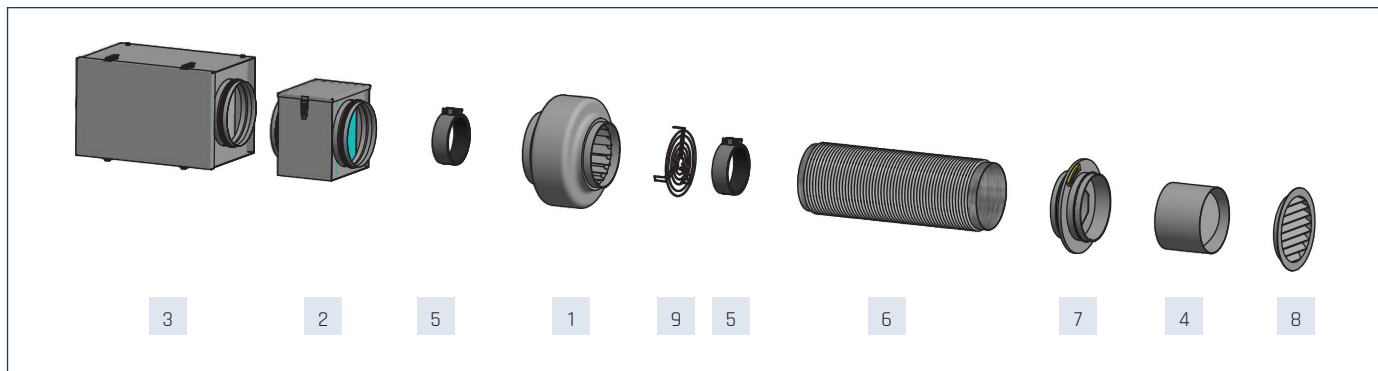

Fan	1	2	3				
			channel filter DF	channel filter DF-K			
				cartridge filter to DF-K			
			EU3	EU5	EU7	EU9	
VENT-100N		40520610	40521710	40520800	40520805	40520810	40520820
VENT-125N		40520620	40521715	40520800	40520805	40520810	40520820
VENT-150N		40520640*	40521720*	40520800*	40520805*	40520810*	40520820*
VENT-160N		40520640	40521720	40520800	40520805	40520810	40520820
VENT-200N		40520640	40521725	40520800	40520805	40520810	40520820
VENT-250N		40520650	40521730	40520800	40520805	40520810	40520820
VENT-315N		40520660	40521735	40520830	40520835	40520840	-
VENT-355N		40520670	40521740	40520830	40520835	40520840	-

Fan	1	4	5	6		7	8	9		
				backdraft shutter CAR-PL	anti-vibration connector ACOP-PL				flexible silencer AKU COMP	
									0,6m	1,2m
						throttle IRIS	vent KWO	protective mesh DEF-VENT		
VENT-100N		40521010-01	40521810	40521510	40521610	19527100	40522520	40522010		
VENT-125N		40521020-01	40521815	40521520	40521620	19527125	40522530	40522011		
VENT-150N		40521029-01	40521818	40521530*	40521630*	19527160*	40522540*	40522012*		
VENT-160N		40521030-01	40521820	40521530	40521630	19527160	40522540	40522012		
VENT-200N		40521040-01	40521825	40521540	40521640	19527200	40522550	40522013		
VENT-250N		40521050-01	40521830	40521550	40521650	19527250	40522560	40522014		
VENT-315N		40521060-01	40521835	40521560	40521660	19527315	40522570	40522015		
VENT-355N		40521065-01	40521840	-	-	-	-	40522133		
VENT-400N		40521070-01	40521845	-	-	19527400	40522580	40522134		

\* Mounting accessories dedicated to 160 mm diameter.

channel filter DF p. 243	channel filter DFK...+EU p. 244	backdraft shutter CAR-PL p. 247	antivibration connector ACOP-PL p. 246	flexible silencer AKU-COMP p. 241	throttle IRIS p. 248	vent KWO p. 661	diffuser AKT/AKK p. 658	protective mesh DEF-VENT p. 246	heater DH/DH-R p. 233



## ELECTRICAL ACCESSORIES

Fan	wall thermostat	duct thermostat	air quality sensor	humidistat	thyristor controller		
	TS	TK-1	SQA	HIG-2	REB N	REB NE	TLR
VENT-100N	40025345	40025330	40025140	40025150	40025010	40025020	40025025
VENT-125N	40025345	40025330	40025140	40025150	40025010	40025020	40025025
VENT-150N	40025345	40025330	40025140	40025150	40025010	40025020	40025025
VENT-160N	40025345	40025330	40025140	40025150	40025010	40025020	40025025
VENT-200N	40025345	40025330	40025140	40025150	40025010	40025020	40025025
VENT-250N	40025345	40025330	40025140	40025150	40025010	40025020	40025025
VENT-315N	40025345	40025330	40025140	40025150	40025030	40025040	40025045
VENT-355N	40025345	40025330	40025140		40025030	40025040	40025045
VENT-400N	-	40025330	-		40025051	40025051	-

Fan	11-speed thyristor regulator	2-adjustable 6-speed thyristor regulator	ERV	transformer regulator		transformer regulator 2-adjustable	
	IRF	RND-1		RMB	RVS	SC2	SC2A
VENT-100N	-	40025630	-	40025060	40025232	40025250	40025251
VENT-125N	-	40025630	-	40025060	40025232	40025250	40025251
VENT-150N	-	40025630	40025046	40025060	40025232	40025250	40025251
VENT-160N	-	40025630	40025046	40025060	40025232	40025250	40025251
VENT-200N	40015154	40025630	40025046	40025060	40025232	40025250	40025251
VENT-250N	40015154	40025630	40025046	40025060	40025232	40025250	40025251
VENT-315N	40015154	40025630	40025046	40025060	40025232	40025250	40025251
VENT-355N	40015154	40025630	40025046	40025060	40025232	40025250	40025251
VENT-400N	40015154	-	40025053	40025070	40025234	40025254	40025255

wall thermostat <b>TS</b> p. 650	duct thermostat <b>TK-1</b> p. 650	air quality sensor <b>SQA</b> p. 645	humidistat <b>HIG-2</b> p. 645	thyristor regulator <b>REB</b> p. 638	thyristor regulator <b>TLR</b> p. 639	regulator <b>IRF</b> p. 639	regulator <b>RND-1</b> p. 641	regulator <b>ERV</b> p. 642	regulator <b>RMB</b> p. 640

regulator <b>RVS</b> p. 640	transformer regulator 2-adjustable p. 641

## ERP CHARACTERISTICS

		RVU*
	Name	VENT-100N
a	supplier name	VENTURE INDUSTRIES / SOLER&PALAU
b	article number	40022200
c	SEC average [kWh/m <sup>2</sup> .a]	-10,5
c	SEC cold	-26,9
c	SEC warm	-1,1
c	SEC class	E
d	device category	RVU
d	device type	UVU
e	type of drive	variable speed drive
f	type of heat recovery system	not applicable
g	thermal efficiency of heat recovery [%]	not applicable
h	maximum flow rate [m <sup>3</sup> /h]	240
i	electric power input [W]	59,2
j	sound power level [dB(A)]	49
k	reference flow rate [m <sup>3</sup> /s]	0,05
l	reference pressure difference [Pa]	168
m	SPI [W/m <sup>3</sup> /h]	0,21
n	control factor	1
o	maximum external leakage for BVU [%]	2
p	mixing rate	not applicable
q	position of visual filter warning	not applicable
r	instructions for installing supply grilles	not applicable
s	internet address	<a href="http://www.ventur.eu">www.ventur.eu</a> / <a href="http://www.solerpalau.com">www.solerpalau.com</a>
t	airflow sensitivity to pressure variation	not applicable
u	Indoor/outdoor air tightness [m <sup>3</sup> /h]	not applicable
v	annual electricity consumption - average climate [kWh/a]	266
v	annual electricity consumption - warm climate [kWh/a]	266
v	annual electricity consumption - cold climate [kWh/a]	266
w	annual heating saved - average climate [kWh/a]	
w	annual heating saved - warm climate [kWh/a]	
w	annual heating saved - cold climate [kWh/a]	
	MISC	1,1
	x-value	2

\* RVU - "residential ventilation unit" - according to COMMISSION REGULATION (EU) No 1253/2014.

## ERP CHARACTERISTICS

NRVU*					
	Name	VENT-125N	VENT-150N	VENT-160N	VENT-200N
a	supplier name	VENTURE INDUSTRIES / SOLER&PALAU	VENTURE INDUSTRIES / SOLER&PALAU	VENTURE INDUSTRIES / SOLER&PALAU	VENTURE INDUSTRIES / SOLER&PALAU
b	article number	40022210	40022211	40022212	40022213
c	device category	NRVU	NRVU	NRVU	NRVU
c	device type	UVU	UVU	UVU	UVU
d	type of drive	variable speed drive	variable speed drive	variable speed drive	variable speed drive
e	type of heat recovery system	not applicable	not applicable	not applicable	not applicable
f	thermal efficiency of heat recovery [%]	not applicable	not applicable	not applicable	not applicable
g	reference flow rate in NRVU [m³/s]	0,05	0,11	0,1	0,14
h	effective electric power input [kW]	0,06	0,09	0,09	0,14
i	SFP <sub>int</sub> [W/(m³/s)]	not applicable	not applicable	not applicable	not applicable
j	face velocity [m/s]	1	1,3	1,2	1,6
k	Δps, ext [Pa]	260	257	264	383
l	Δps, int [Pa]	not applicable	not applicable	not applicable	not applicable
m	Δps, add [Pa]	not applicable	not applicable	not applicable	not applicable
n	static efficiency of fans [%]	26,7	31	31	42,5
o	maximum external leakage rate [%]	2	2	2	3
p	maximum internal leakage rate [%]	not applicable	not applicable	not applicable	not applicable
q	energy performance	not applicable	not applicable	not applicable	not applicable
r	visual filter warning	not applicable	not applicable	not applicable	not applicable
s	L <sub>WA</sub> [dB(A)]	54	55	56	51
	internet address	ventur.eu solerpalau.com	ventur.eu solerpalau.com	ventur.eu solerpalau.com	ventur.eu solerpalau.com

NRVU*					
	Name	VENT-250N	VENT-315N	VENT-355N	VENT-400N
a	supplier name	VENTURE INDUSTRIES / SOLER&PALAU	VENTURE INDUSTRIES / SOLER&PALAU	VENTURE INDUSTRIES / SOLER&PALAU	VENTURE INDUSTRIES / SOLER&PALAU
b	article number	40022214	40022215	40022216	40022217
c	device category	NRVU	NRVU	NRVU	NRVU
c	device type	UVU	UVU	UVU	UVU
d	type of drive	variable speed drive	variable speed drive	variable speed drive	variable speed drive
e	type of heat recovery system	not applicable	not applicable	not applicable	not applicable
f	thermal efficiency of heat recovery [%]	not applicable	not applicable	not applicable	not applicable
g	reference flow rate in NRVU [m³/s]	0,15	0,22	0,36	0,54
h	effective electric power input [kW]	0,15	0,26	0,27	0,54
i	SFP <sub>int</sub> [W/(m³/s)]	not applicable	not applicable	not applicable	not applicable
j	face velocity [m/s]	1,8	1,8	1,8	2,2
k	Δps, ext [Pa]	369	391	251	326
l	Δps, int [Pa]	not applicable	not applicable	not applicable	not applicable
m	Δps, add [Pa]	not applicable	not applicable	not applicable	not applicable
n	static efficiency of fans [%]	42,5	45,4	46,2	50,1
o	maximum external leakage rate [%]	3	3	3	3
p	maximum internal leakage rate [%]	not applicable	not applicable	not applicable	not applicable
q	energy performance	not applicable	not applicable	not applicable	not applicable
r	visual filter warning	not applicable	not applicable	not applicable	not applicable
s	L <sub>WA</sub> [dB(A)]	58	61	55	61
	internet address	ventur.eu solerpalau.com	ventur.eu solerpalau.com	ventur.eu solerpalau.com	ventur.eu solerpalau.com

\* NRVU - "non-residential ventilation unit" - according to COMMISSION REGULATION (EU) No 1254/2014.